

LP3944 Evaluation Kit

National Semiconductor
Application Note 1344
Mary F Kao
October 2004



LP3944 Overview

The LP3944 is an integrated device capable of independently driving 8 LEDs. This device also contains an internal oscillator that provides all the necessary timing required for driving LED. Two prescaler registers along with two PWM registers provide a versatile duty cycle control. The LP3944 contains the ability to dim/blink LEDs in SMBUS/I²C applications. For more information, please refer to the LP3944 datasheet.

Evaluation Kit Overview

LP3944 Evaluation Kit contains the evaluation board and PC software and supports complete functional evaluation of the LP3944. All functions of the chip can be programmed via the use of the I²C interface port. The PC software provided emulates the I²C bus communication protocol. Hand shaking logic to interface to PC's parallel port and all necessary level shifting is provided.

Getting Started

The following instructions show how to use the LP3944 evaluation kit in default conditions. Please use the ESD protection (ground cable) to prevent any unwanted damaging ESD events.

Install the evaluation software on a PC by copying the "LP3944.exe" from the CD to the LP3944 folder in your computer. There are two ways to launch the software. One way is without the evaluation board. Another way is with the evaluation board connected to the cable.

Launching the software without the evaluation board:

1. Start the software by double-clicking on its icon. A message will appear stating that the LP3944 board is not detected, and will ask if the user wants to switch to virtual LED mode. Click "Yes."
2. The default conditions of the virtual LEDs are different than that of the LP3944. Please be aware that the virtual LEDs simulate the functionality of the LP3944, but they do not perform exactly to the specification. To truly evaluate the LP3944, please request for a LP3944 evaluation board.

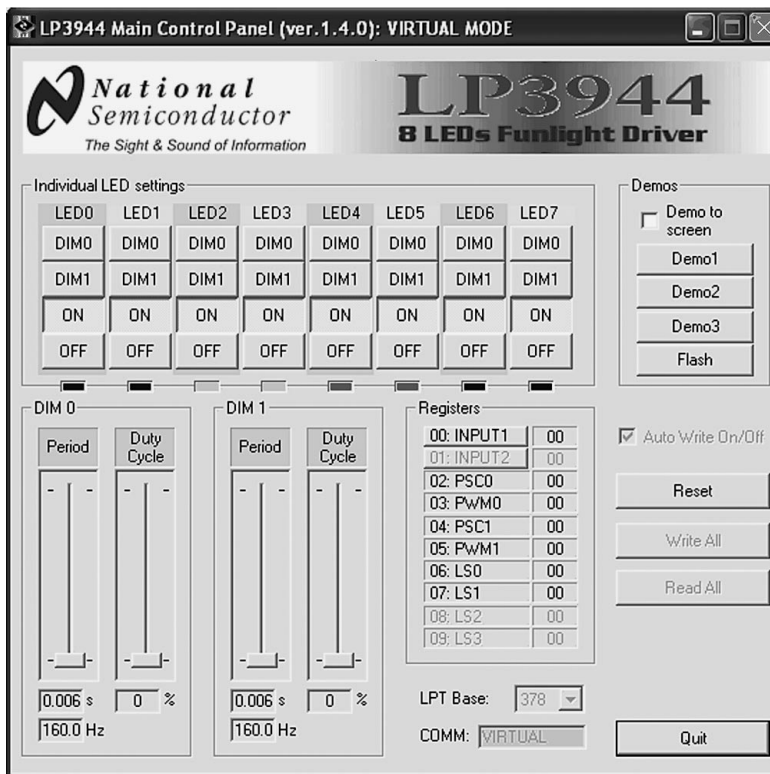

20127401

LP3944 software in virtual LED mode with all LEDs turned on (this is no the default state)

Getting Started (Continued)

Launching the software with the evaluation board connected to the LPT cable:

1. Connect a power supply (typically 5V) to "V_{DD}" and "GND" pins. Power supply's negative terminal should be connected to "GND" and positive to "V_{DD}". This will provide power to the LP3944 and the LEDs. Jumper JP1 should be in the "V_{DD}" position. For added flexibility, a separate power supply can be connected to "VEXT" to supply power to LEDs, with jumper JP1 in the "VEXT" position.
2. The evaluation board is now ready for operation. Turn on the power supply.
3. Connect the LPT cable to the evaluation board and the LPT port of your PC.
4. Start the software by double-clicking on its icon.
5. The evaluation kit is now ready to use and the LP3944 can be programmed and controlled through the PC software.

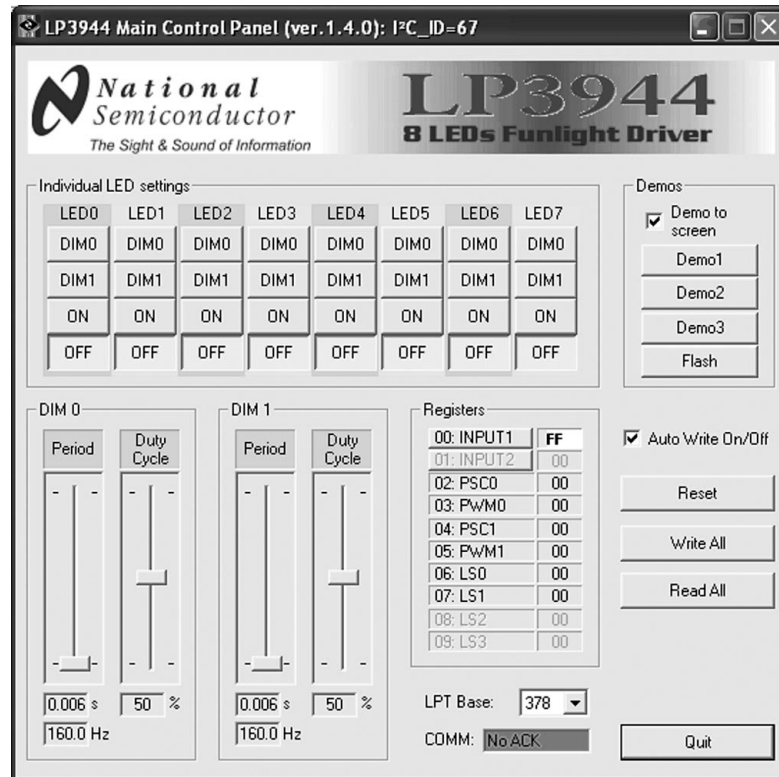

20127402

LP3944 software launched with evaluation board connected to LPT cable (in default state).

The Control Panel

Individual LED settings—allows the user to program LED0 to LED7 by turning it on or off or dimming/blinking at a specified rate. DIM0 corresponds to the values programmed in PWM0 and PSC0 registers. DIM1 corresponds to the values programmed in PWM1 and PSC1 registers. The default state is off for all LEDs.

DIM0—The sliding bars control the PSC0 and PWM0 registers. The PSC0 register is used to program the period of DIM0 (6.25 ms to 1.6s). The PWM0 register is used to program the duty cycle of DIM0 (0% to 100%). The default values are 6.25 ms and 50% duty cycle.

DIM1—The sliding bars control the PSC1 and PWM1 registers. The PSC1 register is used to program the period of DIM1 (6.25 ms to 1.6s). The PWM1 register is used to program the duty cycle of DIM1 (0% to 100%). The default values are 6.25 ms and 50% duty cycle.

Registers—This display shows the current status of the ten registers (in hex) in the LP3944. Registers 00 and 01 are read-only registers that can be updated by clicking on the buttons. The other registers can be updated by clicking on "Read All."

COMM—Message indicating proper/improper I²C communication. Upon successful communication, "Ack OK" with green background will be displayed. Otherwise, "NoAck" with red background will be displayed. Errors include absence of power supply to the evaluation board, absence of LPT cable connection, and wrong LPT port address.

LPT Base—Three options for LPT port setting. Default value is 378.

Demos to screen—By selecting this option, the individual LED settings panel will become active to reflect the states of LEDs in demos.

The Control Panel (Continued)

Demo1—Music demo. Soundcard needed to activate the button to play. The LEDs are controlled by the amplitude of the music.

Demo2—Music demo. Soundcard is needed to activate the buttons to play. The LEDs will light up in circle as music progresses.

Demo3—Non-music demo to illustrate dimming effect of LEDs.

Flash—The RGB LED will all turn on to create a flashlight effect.

Auto Write On/Off—When auto write feature is on (the box is checked), any change will take place immediately. If auto

write is off (the box is not checked), changes will take place only after pressing "Write All." Any LED that is programmed while auto write is off will only take place if "Write All" button is pressed before auto write is on; otherwise, these LEDs will go back to their previous states.

Reset—Resets the LP3944 in its default state and erases all previously programmed value on the control panel to reflect the LP3944 default state.

Write All—All programmed values on the control panel will be executed when this button is pressed.

Read All—All ten registers will be read from the chip to refresh the control panel when this button is pressed.

Quit—Quits the program.

Bill Of Material for LP3944

Designator	Description	Footprint	Comment
C1, C3, C4, C5, C6, C7	0.1 μ F, ceramic	0805	TDK
C2, C8	2.2 μ F	0805	TDK
R0, R1, R4, R6, R7	82 Ω	0603	
R2	121 Ω	0603	
R3	140 Ω	0603	
RSCL, RSDA	2.2k	0603	
RA0, RA1, RA2	100k	0603	
K1	DB25T		
D1, D2	SCHOTTKY Rectifier	805 2x	On Semi MBRM120
JP1	HEADER 2X2		
LED0 - LED15	green, red, blue or white	0805 2x	Vishay or Osram
U2	Level Shifter	0.15" SOIC16	On Semi MC14504B
U3	Level Shifter	0.15" SOIC16	On Semi MC14504B
U4	3 state quad buffers	0.15" SOIC14	Fairchild MM74HC125M
U1	LED driver	SQA24	NSC LP3944ISQ

LP3944 Evaluation Board Schematic

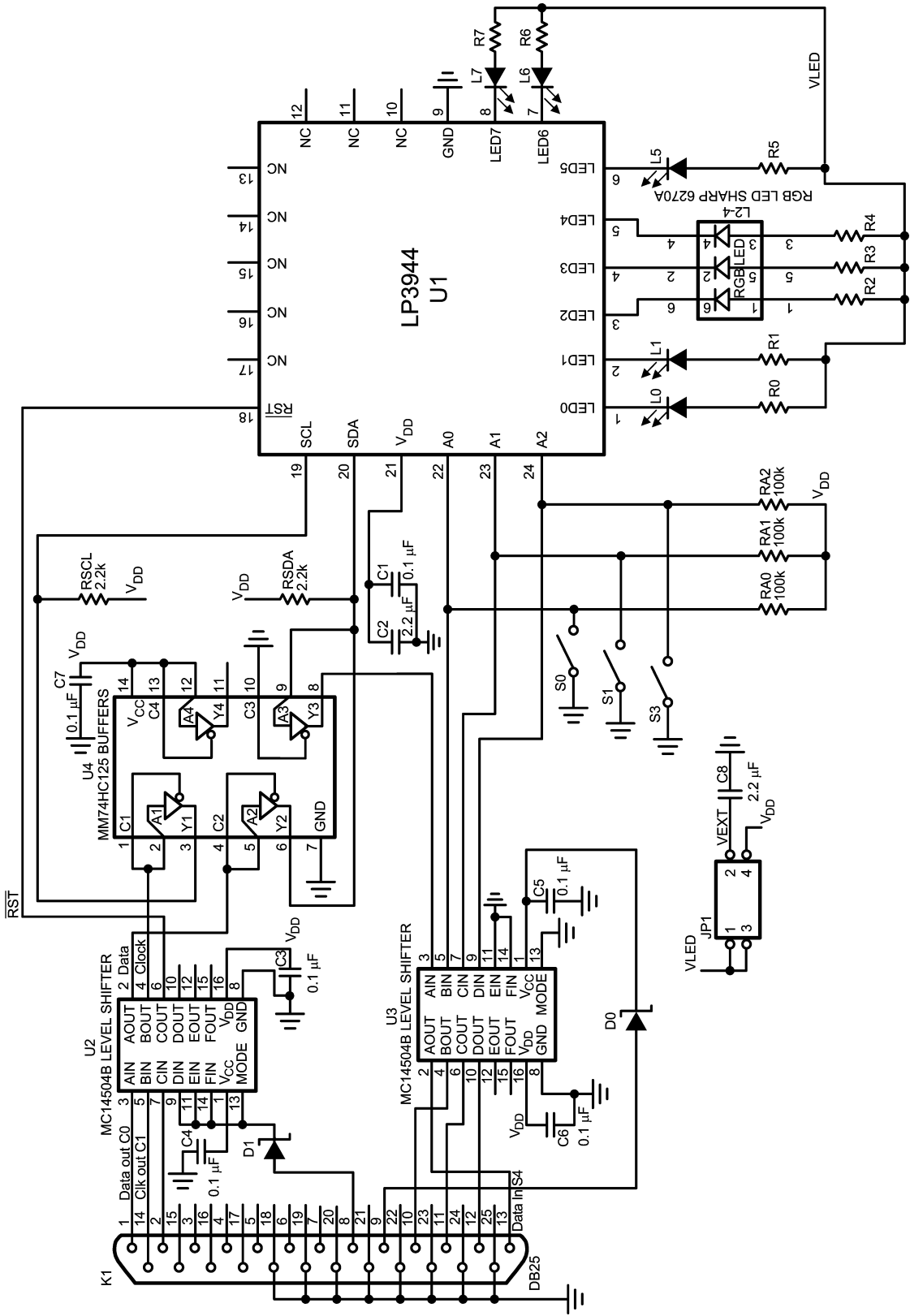

National does not assume any responsibility for use of any circuitry described, no circuit patent licenses are implied and National reserves the right at any time without notice to change said circuitry and specifications.

For the most current product information visit us at www.national.com.

LIFE SUPPORT POLICY

NATIONAL'S PRODUCTS ARE NOT AUTHORIZED FOR USE AS CRITICAL COMPONENTS IN LIFE SUPPORT DEVICES OR SYSTEMS WITHOUT THE EXPRESS WRITTEN APPROVAL OF THE PRESIDENT AND GENERAL COUNSEL OF NATIONAL SEMICONDUCTOR CORPORATION. As used herein:

1. Life support devices or systems are devices or systems which, (a) are intended for surgical implant into the body, or (b) support or sustain life, and whose failure to perform when properly used in accordance with instructions for use provided in the labeling, can be reasonably expected to result in a significant injury to the user.
2. A critical component is any component of a life support device or system whose failure to perform can be reasonably expected to cause the failure of the life support device or system, or to affect its safety or effectiveness.

BANNED SUBSTANCE COMPLIANCE

National Semiconductor certifies that the products and packing materials meet the provisions of the Customer Products Stewardship Specification (CSP-9-111C2) and the Banned Substances and Materials of Interest Specification (CSP-9-111S2) and contain no "Banned Substances" as defined in CSP-9-111S2.



National Semiconductor
Americas Customer
Support Center
 Email: new.feedback@nsc.com
 Tel: 1-800-272-9959

www.national.com

National Semiconductor
Europe Customer Support Center
 Fax: +49 (0) 180-530 85 86
 Email: europe.support@nsc.com
 Deutsch Tel: +49 (0) 69 9508 6208
 English Tel: +44 (0) 870 24 0 2171
 Français Tel: +33 (0) 1 41 91 8790

National Semiconductor
Asia Pacific Customer
Support Center
 Email: ap.support@nsc.com

National Semiconductor
Japan Customer Support Center
 Fax: 81-3-5639-7507
 Email: jpn.feedback@nsc.com
 Tel: 81-3-5639-7560